

## E-Case Accessories

This data sheet covers optional **Linc-lug mounting brackets, plastic bezels and waterproof gaskets** for the E-Case range of enclosures.

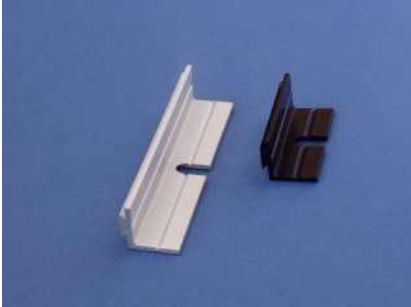

**Linc-lug mounting brackets**



**plastic bezels**

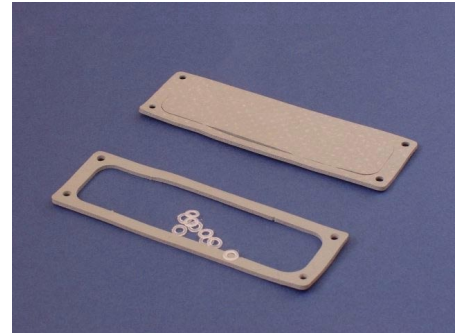

**gaskets**

## Linc-Lugs

Aluminium extruded mounting bracket for fixing E-Case housings to walls, panels, vehicle bulkheads etc. Linc-Lug slides into any external dovetail feature on E-Case housings and is retained by the end plates. The silver lugs are strip silver anodized and are used with the silver E-Case enclosures that are anodized in the same way. The black lugs are individually black anodized like the black boxes in the E-Case range.

**Linc-Lug Order Codes:**

length	black	silver
40mm	<b>LSB 40</b>	<b>LSS 40</b>
80mm	<b>LSB 80</b>	<b>LSS 80</b>
40mm pair with screw	<b>MTB40</b>	<b>MTS40</b>

**MTS40 type lug**



**Non-Standard Lengths:** Available, but not with U-shaped slot. Ask for a quotation.

**Material:** Aluminium 6063 T6 (HE9).

**Finish:** LSS40, LSS80, MTS40 - Silver anodized 5 µm thickness. (Cut ends and inside of U-shaped slot are not anodized.) LSB40, LSB80, MTB40 - Black anodized 20µm.

**Weight:** LSS40, LSB 40 - 7.5g. LSS 80, LSB 80 - 15g  
MTS40, MTB40 (pair of lugs in plastic bag) - 15g

**Extrusion Perimeter:** 70mm

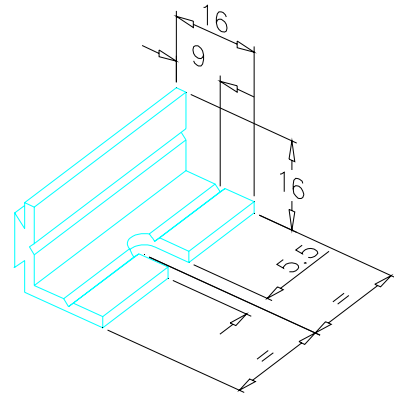

**Application Information:** Linc-Lug is secured as follows:

*either*

1. For cases length 40mm and 80mm, use Linc-Lugs of appropriate length, retain with the end plates.
  2. For cases length 160mm, use more than one Linc-Lug in each slot, retain with the end plates
- or*

Drill a hole 2.6mm diameter through the dovetail on the Linc-Lug using the V-groove as a drill start. Slide the drilled lug to the desired position along a selected enclosure. Drive a No.4 x 1/4" posi-pan type B self-tapping screw into the drilled hole to securely wedge the Linc-Lug in the dovetail slot.

**MTS40** lugs are now available with screws pre-fitted. These are supplied as a pair in a plastic bag.

## Bezels

Cosmetic end plate surrounds made of ABS plastic that are available in four sizes to suit the four extrusion profiles. The four end-plate mounting screws pass through the bezel, through the end-plate and into the extrusion. The screw heads are concealed by inserts which closely match the bezel. This gives a much-improved cosmetic appearance.

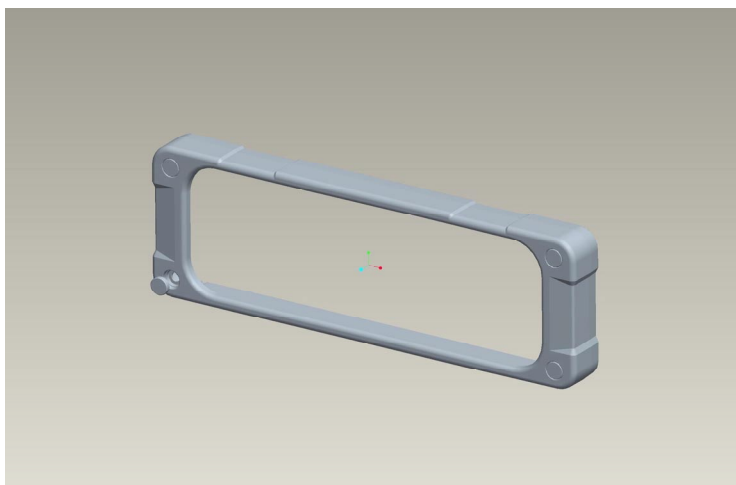

**Bezel Order Codes:**

	<b>Black</b>	<b>Silver</b>
<b>E-Case A</b>	<b>ZAB1</b>	
<b>E-Case B</b>	<b>ZBB1</b>	
<b>E-Case C</b>	<b>ZCB1</b>	<b>ZCS1</b>
<b>E-Case D</b>	<b>ZDB1</b>	<b>ZDS1</b>

**Application Information:**

The bezels come with the four inserts attached to a sprue on the bezel. The sprue should be cut off the bezel using a sharp knife. Similarly the inserts should be cut off the sprue. Care should be taken not to leave plastic pips on the inserts that will prevent them lying flush when later inserted in the bezel. Once inserted, the inserts are not intended to be removed, but actually it *is* possible to remove them without damage by carefully using a pin.

Bezels have a few applications that are worth particular mention. It is usual to put script on the front plate of an electronics housing. This can be done by screen printing the plates, but an alternative method is to reverse print the back side of a clear polycarbonate sheet. This can be cut and stuck on the end plate. The bezel is used to conceal the cut edges. Another application of the bezels is to conceal the edge of a gasket that would normally be visible sandwiched between the end plate and the extrusion. There are more details in the gasket section.

**Black bezel on E-Case C (typical application)**



**Silver bezel on E-Case D**



## Gaskets

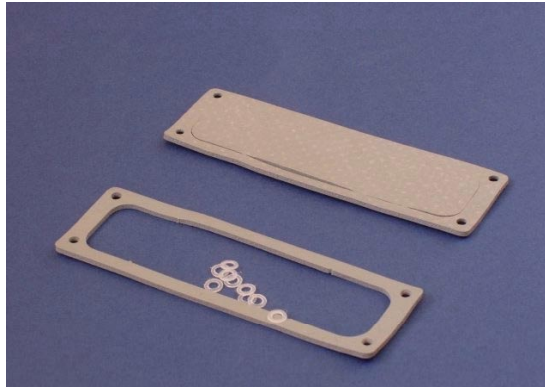

Gaskets come as a set suitable for waterproofing one enclosure. A set comprises two white silicon foam gaskets and a number of polythene washers. The washers are optionally fitted under the heads of the screws and raise the rating of the gasket set from IP65 to IP66.

### Gasket Set Order Codes:

	Order Code
E-Case A	GEA1
E-Case B	GEB1
E-Case C	GEC1
E-Case D	GED1

### Application Information:

The E-Case range was not originally designed to be waterproof. Even with a gasket seal around the edge of the profile water could enter under the heads of the screws and enter the enclosure through the open screwport. The original waterproof enclosure range was the Linc-Ace range which had drilled 'blind' holes for the screws. Even if these holes filled with water, it did not enter the main part of the enclosure. Linc-Ace was a heavy extrusion, costly to manufacture and is now obsolete.

Use of a flat gasket will render the enclosure "waterproof" to IP65 and addition of a washer under each screw will give an increased rating of IP66. Use of these gaskets will not reliably give a rating of IP67. If you type (say) "IP66" into Google Search Engine you will be able to find a definition of IP66 which most engineers will have trouble relating to their practical application. In practice, it has been found that the following applies:

A diecast aluminium enclosure with a rating of IP67 was put under 1 metre of water for 24 hours with no water ingress.

An E-Case enclosure with a rating of IP66 was put under 1 metre of water for 24 hours and it contained a few drops of water (say 0.1ml).

An E-Case enclosure with a rating of IP65 when put under water took a few minutes to fill up.

These results, which have been found in practice, probably exceed the strict requirements of the IP rating, but this gives a margin of confidence. The diecast enclosure is better than an E-Case enclosure because one half of the sealing surface (metal to rubber) is a smooth (die-cast) metal ridge whereas on an extrusion it is a cut face. It has small saw cut marks on the sealing surface which will not be completely filled by the gasket thus forming small channels from the outside to the inside of the box. Normally, surface tension will prevent water flowing down these channels, but under pressure water might flow. In order to get round this one might consider a liquid gasket compound painted on to the end of the extrusion. This will also help align the gasket on the extrusion prior to fitting the end plate.

Another feature of the flat gasket is that it needs to be fitted with some care – it has offset holes and needs orienting like the end plate. Also, failure to completely screw down one screw will reduce the IP rating and this will not be obvious when inspected. On-the other hand a diecast enclosure is fool proof. However, it is very ugly, and all the holes for the connectors have to be individually machined, whereas end plates can be mass-produced, complete with connector holes, by using a cnc punch.

It should be noted that if a bezel is to be used then the four washers can be omitted from under the screw heads. The plastic of the bezel gets squeezed under the screw heads and makes a seal. The benefit of the bezel is that it conceals the gasket in applications where appearance is important.

### **Practical Advice on Waterproofing.**

There are occasions when an enclosure can be too waterproof. Water somehow gets into the enclosure and cannot get out. A common cause of failure in these situations is that a copper track on a circuit board dissolves under water.

Example 1: A hand made racing motorcycle ignition system made with a die-cast box where the lid has been sealed with epoxy. Unit has failed and was found to be full of water – circuit board track had dissolved.

Example 2: Linc-Ace system (now obsolete) with flat gasket used for another motorcycle ignition system on an American bike. Driving rain would cause the unit to fail (and *what* a time to fail).

Example 3: On site external wireless security system powered by 12v derived from a small plug-in mains transformer. The housing was a plastic IP67 enclosure. The unit was found to fail after 12 months and when opened the sachet of silica gel inside was found to have turned to liquid. If you put silica gel in your electronics, then you know you have a problem. Even if the enclosure was IP67, once the hole has been made for the antenna, it may not be IP67 any more. The solution was to drill a 12mm hole in the bottom and glue some mesh across to discourage spiders, and to put a gold coloured metal-clad resistor in the unit. The resistor was placed low down and to one side to encourage air circulation and the value was selected so that it dissipated a watt or so – quite enough to keep the atmosphere inside from condensing. No units have failed for seven years.

Product and data subject to change without notice. User knows application and must determine fitness for purpose and appropriateness of advice verbal or written. See terms and conditions of sale.

© Lincoln Binns Ltd. 2005